

6-22-187
SHEET 1

**UNDERGROUND SECTIONALIZING**  
 Customer Reference Specification  
 Install 3-Phase, 200 Amp Switchgear Foundation

6-22-187
SHEET 1

INSTALLATION INSTRUCTIONS FOR  
  
 3-PHASE, 200 AMP  
  
 SWITCHGEAR FOUNDATION

REPLACES CRS-1006  
 406C-187

DISTRIBUTION CONSTRUCTION SPECIFICATIONS  <b>PPL ELECTRIC UTILITIES          CORPORATION</b>	Date: <u>11/21/08</u> Drafter: <u>RRC</u> <span style="float: right;">6-22-187_S001.dwg</span>
	Sponsor: _____ Approved: <u>Mark R. Bennett</u> Manager-Distribution Maintenance

6-22-187
SHEET 2

**UNDERGROUND SECTIONALIZING**  
Customer Reference Specification  
Install 3-Phase, 200 Amp Switchgear Foundation

6-22-187
SHEET 2

This specification contains basic information which defines PPL EU's material and design requirements for the installation of 3-phase, 200 amp switchgear foundations.

All details of this specification shall be strictly followed. Any deviation **must** be approved by a PPL EU's engineer. Unapproved deviations are usually costly for the customer to correct and can result in delays or possible refusal to connect service.

**Other Associated Specifications**

- CRS 6-15-180.....Customer-Installed Duct Systems
- CRS 6-18-115.....Installation Instructions for Customer-Installed Conduit Systems on PPL EU Terminal Poles
- A-190974.....Concrete Specifications
- CRS 6-17-122.....Three-Phase Padmounted Transformer Installations 75 KVA to 2500 KVA Capacity
- CRS 6-14-125.....Customer-Installed Screening of Padmounted Devices

**General Instructions for Typical Installation**

**1. Plot Plan**

The customer must provide PPL EU with a detailed plot plan showing location of building and property lines, service entrance switchgear, metering, and service entrance.

**2. Construction Plan**

A PPL EU engineer will provide the customer with a construction plan showing the proposed location of primary supply circuits, primary supply conduits, and 200 amp switchgear foundation. Switchgear foundation must always be located in an area where there is free access for PPL EU's mobile crane and maintenance vehicles.

**3. Right-of-Way**

When the customer and PPL EU reach final agreement on location of electric facilities, the customer signs associated agreements and grants necessary right-of-way. Construction by PPL EU will not proceed until these documents are completed by the customer.

**4. Precast Foundation**

The customer's contractor is responsible for purchasing the precast foundation for the 200 amp switchgear. A list of PPL EU approved suppliers is contained on sheet 5. Contractor must be coordinate site preparations with desired delivery date. If site preparations are complete, supplier will set foundation in final position. The contractor must provide a clear and firm approach to the point of delivery.

DISTRIBUTION CONSTRUCTION SPECIFICATIONS  <b>PPL ELECTRIC UTILITIES CORPORATION</b>	Date: <u>11/21/08</u> Drafter: <u>RRC</u> 6-22-187_S002.dwg
	Sponsor: _____ Approved: <u>Mark R. Benner</u> Manager-Distribution Maintenance

6-22-187
SHEET 3

UNDERGROUND SECTIONALIZING  
Customer Reference Specification  
Install 3-Phase, 200 Amp Switchgear Foundation

6-22-187
SHEET 3

### 5. Excavation for Switchgear Foundation

The customer's contractor is responsible for the excavation to install the foundation and for backfill afterwards. The excavation should be at least 7 feet by 9 feet by 56 inches deep. See note 7 for ground ring excavation.

Note: Actual excavation depth may vary from site to site depending upon difference between existing and final grade at time of delivery.

A 6-inch layer of #1B crushed stone is spread to level the bottom of the excavation and act as a French drain. The bottom must be well tamped and level.

### 6. Finished Grade

Finished grade around the switchgear must be approximately 4 inches below top surface of the foundation and sloped away. Never grade the area surrounding foundation in such a way that it forms a swale where ground water will collect.

### 7. Excavation for Ground Ring

The customer's contractor digs trench around foundation (2 feet deep and 4 feet off sides) for installation of ground ring provided by PPL EU. The contractor notifies PPL EU when trench is opened. After PPL EU installs grounding, the contractor backfills trench.

### 8. Conduit System

The customer's contractor installs conduit systems in accordance with PPL EU construction plan. All conduits must enter foundation through wall knock-out areas at locations specified by PPL EU engineer. Never penetrate floor or corners. PPL EU engineer will specify number and size of conduits to be installed.

Contractor must use one of the following methods to install conduit:

- A. Hot dipped galvanized steel conduit (rigid or intermediate grade) directly buried in earth. All threaded couplings must be tightly joined using plumbers teflon tape or similar joint compound designed to stop water leaks. All bends must have at least 36-inch radius. All steel conduits must have grounding bushings at foundation.
- B. Use type EB or DB PVC conduit encased in a concrete envelope as specified in 6-15-180. All joints must be tightly sealed using the appropriate solvent cement. All 90° bends must be hot dipped galvanized steel (rigid or intermediate grade) with at least a 36-inch radius. Concrete must also encase steel bends to prevent cable pulling tensions causing breakage at steel-to-plastic adaptors. All plastic conduit must have bell-ends at the foundation.

After installation, the contractor must clean debris from the ducts by pulling a stiff bristled brush and some clean rags through each conduit. A fish line (mule tape) must be provided in each conduit and all conduit ends must be temporarily plugged to keep them clean and dry.

<b>DISTRIBUTION CONSTRUCTION SPECIFICATIONS</b>  <b>PPL ELECTRIC UTILITIES CORPORATION</b>	Date: <u>11/21/08</u> Drafter: <u>RRC</u> <span style="float: right;">6-22-187_S003.dwg</span>
	Sponsor: _____ Approved: <u>Michael J. Berman</u> Manager-Distribution Maintenance

Regardless of which conduit installation method is used, contractor must seal and waterproof foundation knock-out area around the conduit penetration.

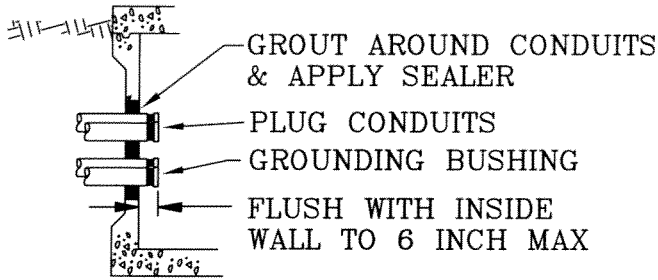

**Figure 1**  
**Steel Conduits**

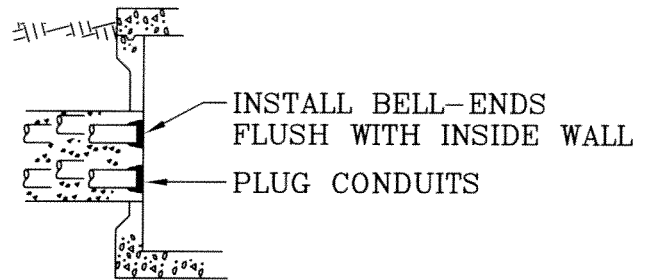

**Figure 2**  
**PVC-Encased**

**9. Notification to PPL EU of Foundation Delivery Time**

It is the customer's responsibility to ensure that precaster notifies PPL EU 24 hours prior to delivery to job site. PPL EU representative will be at job site during precaster's permanent placement of foundation. All approved precasters have names and phone numbers of appropriate PPL EU personnel to be notified.

**10. Protective Barriers**

It is the customer's responsibility to install protective barriers. Barriers are required when the switchgear is located in an area exposed to vehicular traffic. Barriers must be located and installed in accordance with the PPL EU construction plan.

**11. Clearances**

The minimum clearances shown in this specification were set by PPL for operating and maintenance purposes. It is the customer's responsibility to comply with the National Electrical Code (NEC), local municipal, fire insurance regulations and any other applicable code regarding the location of electrical equipment and building facilities. Any required safeguards, such as barriers, are installed and maintained by customer.

**12. Cover and Concealment**

12.1 The customer must keep the area above the switchgear clear of obstructions. This includes overhanging tree limbs which may block crane access to the switchgear.

12.2 The customer may elect to install shrubbery screening or concealment fences. All construction and maintenance work must be performed by the customer. Minimum clearances to the switchgear are shown in CRS 6-14-125. Customer must secure PPL EU approval **before** concealing the switchgear.

DISTRIBUTION CONSTRUCTION SPECIFICATIONS  <b>PPL ELECTRIC UTILITIES CORPORATION</b>	Date: <u>11/21/08</u> Drafter: <u>RRC</u> <span style="float: right;">6-22-187/S004.dwg</span>
	Sponsor: _____
	Approved: <u>Mark R. Benner</u> Manager-Distribution Maintenance

**13. ORDER INFORMATION**

Order from these approved suppliers only. Foundation same as PPL EU CID No 161251 per PPL EU Drawing LD17620. Allow approximately 3 days to coordinate delivery.

- |  |   |
|--|---|
| <p>1. Rotondo Precast<br/>       P.O. Box 210<br/>       514 Township Line Road<br/>       Telford, Pa 18969<br/>       (215) 257-8081</p> <p>2. A.C. Miller Concrete Products, Inc.<br/>       Bridge St.<br/>       Spring City, Pa 19475<br/>       (610) 948-4600<br/>       ATTN: Dennis Miller</p> <p>3. Monarch Products Co., Inc.<br/>       385 Sipe Road<br/>       York Haven, Pa 17370-9705<br/>       (717) 938-8303</p> <p>4. Monarch Precast Concrete Corp.<br/>       425 North Dauphin Street<br/>       Allentown, Pa 18109-2199<br/>       (610) 435-6746</p> | <p>5. Binghamton Precast &amp; Supply<br/>       Phelps Street<br/>       Binghamton, NY 13901<br/>       (607) 722-0334</p> <p>6. By-Crete<br/>       517 King Street<br/>       Lebanon, Pa 17042<br/>       (717) 866-7690</p> <p>7. Modern Precast Concrete Products<br/>       &amp; Construction Supplies<br/>       2863 Brodhead Rd<br/>       Bethlehem, Pa 18020<br/>       (610) 997-3119</p> <p>8. Scranton Craftsmen, Inc.<br/>       930 Dunmore Street<br/>       Throop, Pa 18512<br/>       (800) 775-1479</p> |
|--|---|

**Figure 3  
 Customer-Installed Precast Foundation**

MINIMUM EXCAVATION

7' x 9' x 56" DEEP  
 NOTE 5

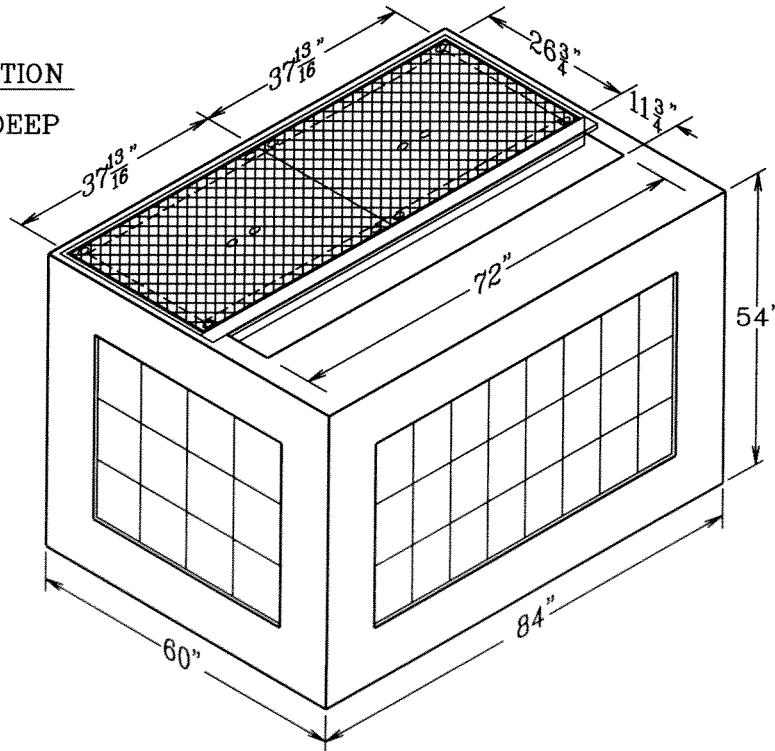

**Figure 4**  
**Typical Installation**

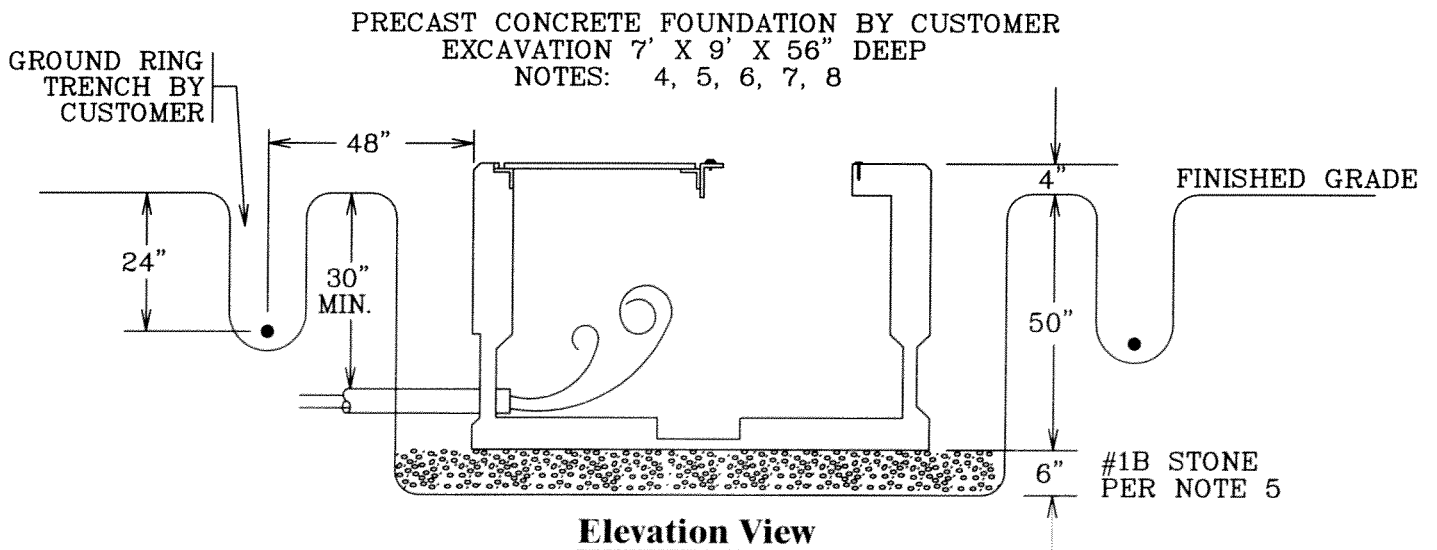
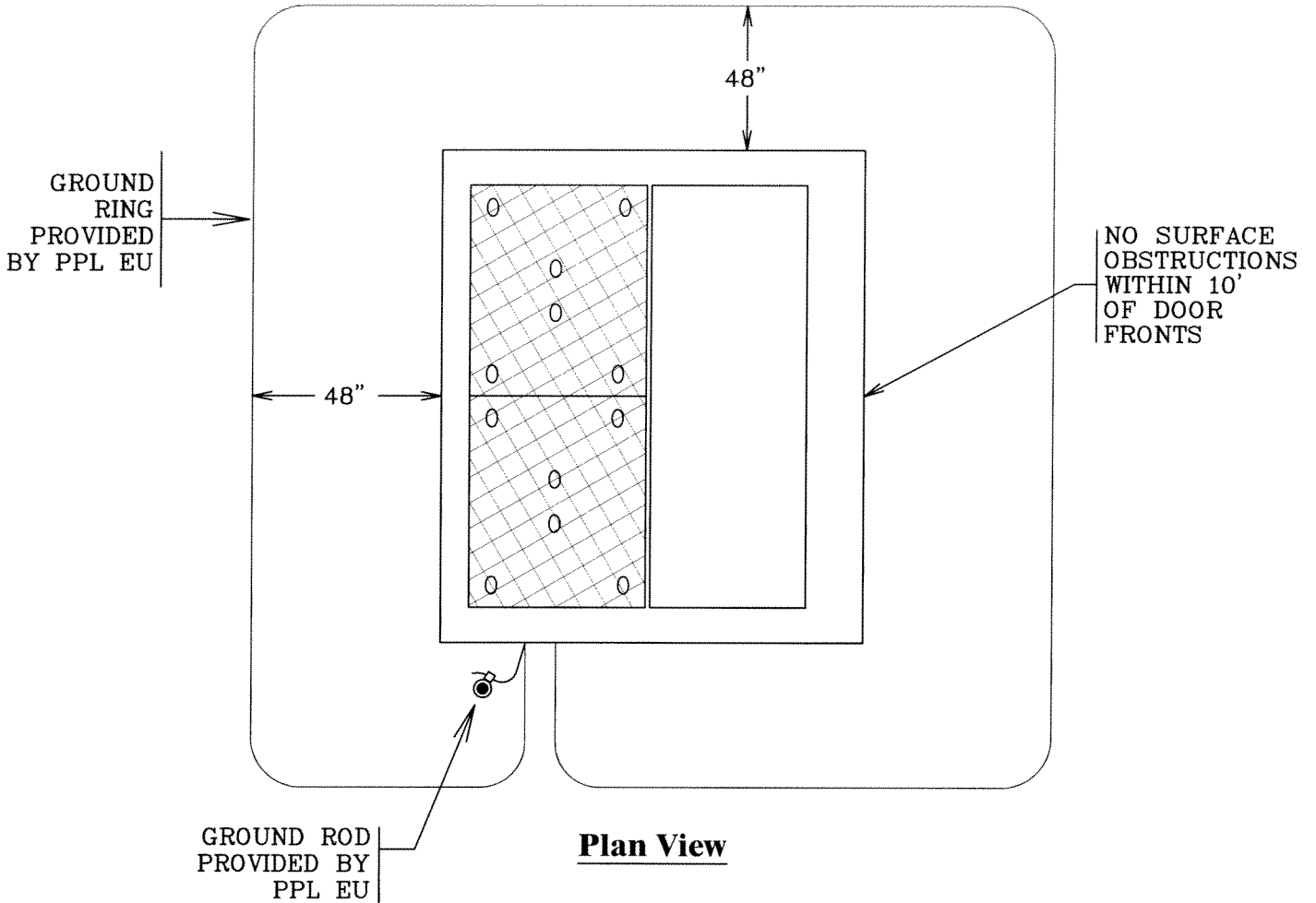

**Figure 5**  
**Barrier and Grounding Details**

