



**Underground Structural  
Customer Reference Specification  
Installed Precast Manhole Specification  
6-15-160**

0000-000-ST-6015  
Custom ID: DCS 6-15  
Revision: 06  
Effective Date: 5/25/2020  
Page 42 of 58

**6-15-160 – Customer Reference Specification Installed Precast Manhole Specification**

**Customer Installed Precast Manhole**

THIS CUSTOMER REFERENCE SPECIFICATION (CRS) IS PART OF THE  
RULES FOR ELECTRIC METER AND SERVICE INSTALLATION (REMSI) WEBSITE.



**Underground Structural  
Customer Reference Specification  
Installed Precast Manhole Specification  
6-15-160**

0000-000-ST-6015  
Custom ID: DCS 6-15  
Revision: 06  
Effective Date: 5/25/2020  
Page 43 of 58

This specification contains basic information which defines PPL material & design requirements for the installation of a precast concrete manhole. Precast concrete manholes must meet H-25 loading requirements.

All details of this specification shall be strictly followed. Any deviation must be approved by a PPL EU engineer. Unapproved deviations are usually costly for the customer to correct & can result in delays or possible refusal to connect service.

**Other Associated Specification**

6-15-180 – Customer Installed Duct System

6-18-115 – Installation Instructions for Customer-Installed Conduit System on PPL Terminal Poles

A190974 – Concrete Specification

**Notes For Precast Manhole Installation**

1. Construction Plan

PPL will provide the customer with a construction plan showing the proposed location of the manhole. Any deviation from the proposed location, due to on-site obstructions, must be approved by PPL.

2. Excavation

Excavate to provide 12-inch clearance all around manhole. Depth as required.

3. Backfill

Backfill using crushed stone to approximately ½ the excavation depth. Remove shoring and tamp or rod the stone to be sure it flows into all voids. Complete backfill to top of manhole.

4. Sump

Unless specified by PPL engineer, do not open sump knockout in foundation.

5. Precast Manhole Installation

The customer's contractor is responsible for purchasing the precast manhole. The contractor must coordinate site preparations with desired delivery date. If site preparations are complete, supplier will set manhole in final position. Contractor must provide a clear & firm approach to the point of delivery. See REMSI website for a list of approved suppliers.

6. Customer is responsible for grounding and installing PPL supplied equipment per PPL specification.



**Underground Structural  
Customer Reference Specification  
Installed Precast Manhole Specification  
6-15-160**

0000-000-ST-6015  
Custom ID: DCS 6-15  
Revision: 06  
Effective Date: 5/25/2020  
Page 44 of 58

**Approved Suppliers**

1. Oldcastle  
200 Keystone Drive  
Telford, PA 18969  
(215) 257-8081
2. A. C. Miller Concrete Product, Inc.  
Bridge Street  
Spring City, PA 19432  
610-948-4600
3. Terre Hill Concrete Products, Inc.  
P.O. Box 10  
Terre Hill, PA 17581  
717-445-3100
4. Monarch Products, Inc.  
385 Sipe Road  
York Haven, PA 17570  
717-938-9303
5. Monarch Precast Concrete Corp.  
425 North Dauphin Street  
Allentown, PA 18109  
610-435-6746
6. Modern Precast Concrete Products  
& Construction Supplies  
2863 Brodhead Road  
Bethlehem, PA 18020  
616-997-3119
7. Scranton Craftsmen, Inc.  
930 Dunmore Street  
Throop, PA 18512  
800-775-1479

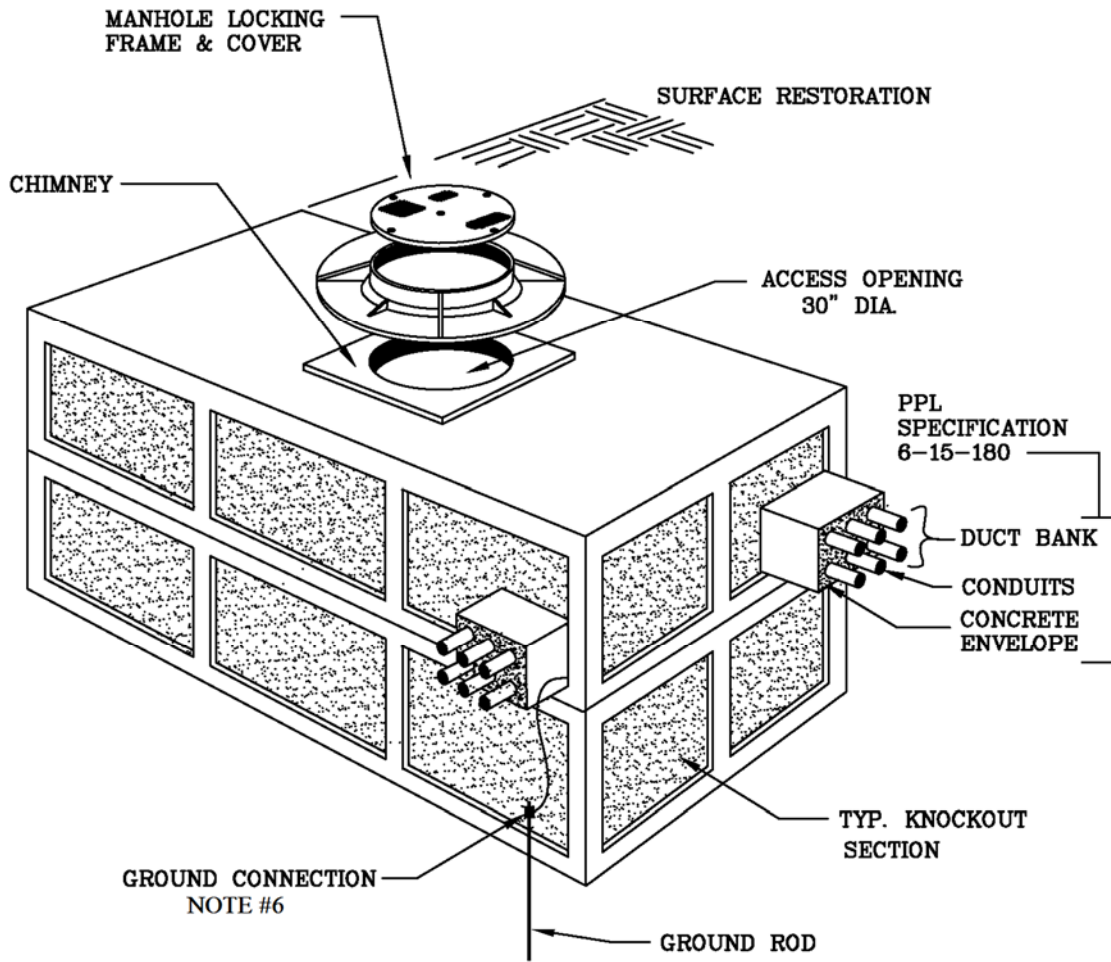

NOTE - INTERIOR LENGTH, WIDTH & HEIGHT AS SPECIFIED BY PPL

6-15-160-A

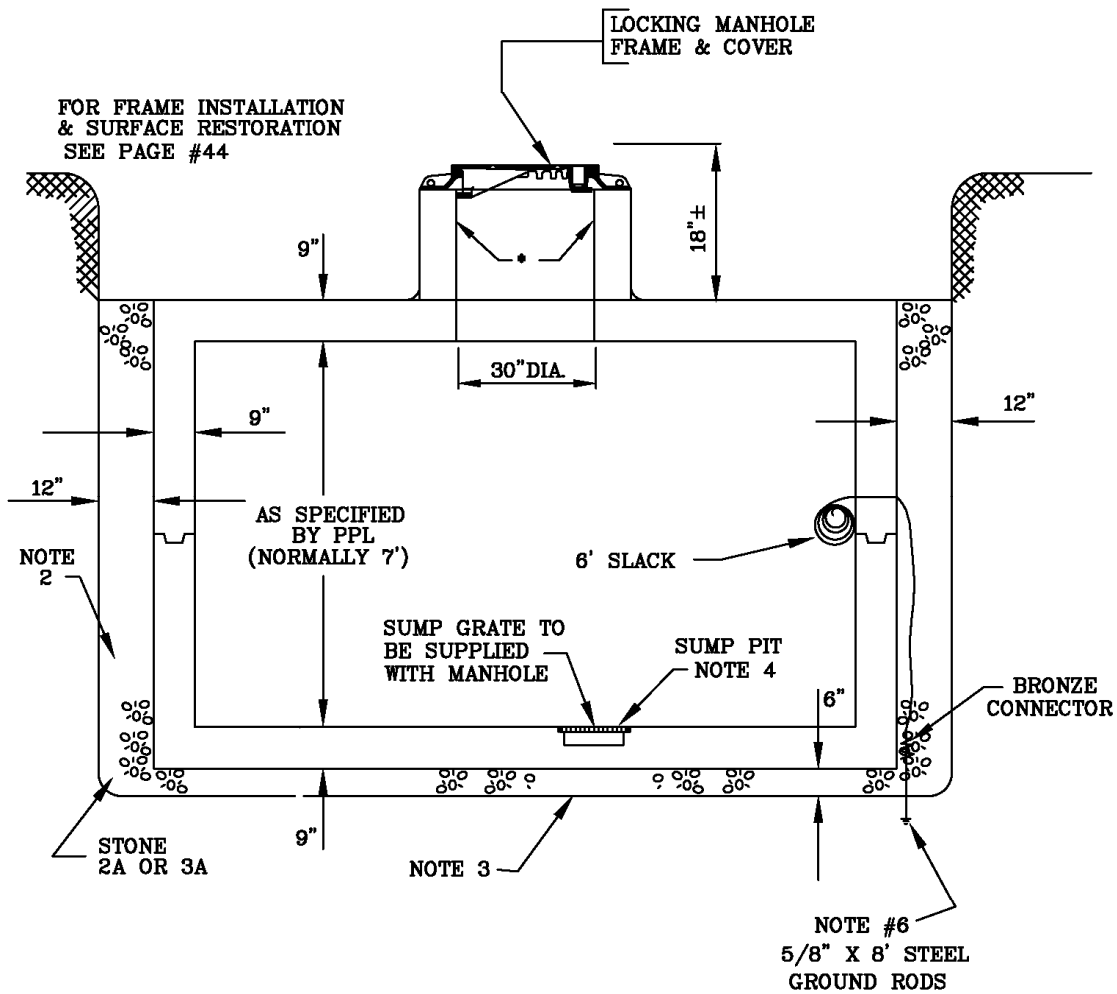

- POUR CONCRETE TO FILL AREA UNDER FRAME SOLIDLY. EXPANDABLE METAL FORM SHOULD BE USED IN THE MANHOLE ENTRANCE TO PROVIDE A SMOOTH THROAT

6-15-160-B

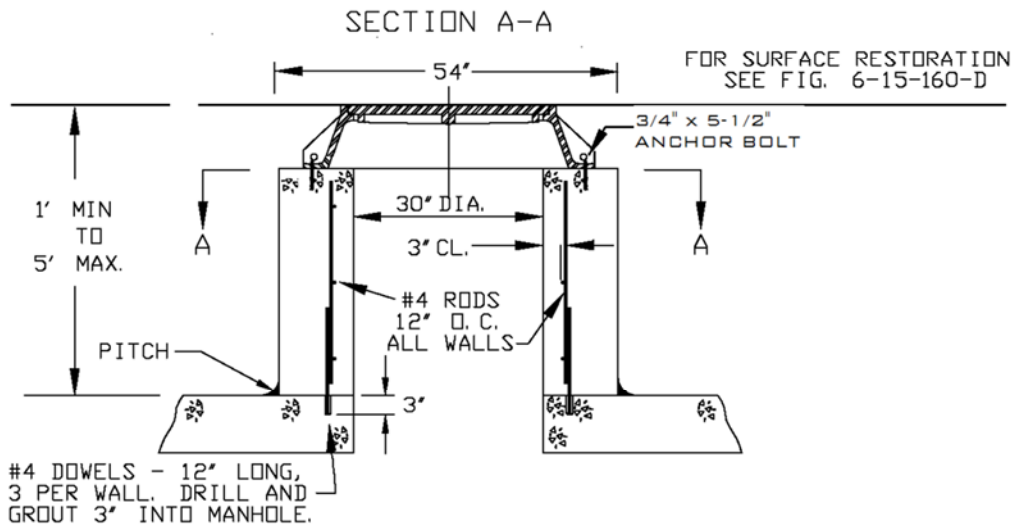
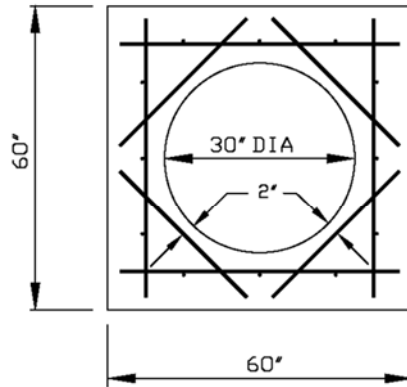

PRECAST MANHOLE

6-15-160-C



PPL Electric Utilities

# Underground Structural Customer Reference Specification Installed Precast Manhole Specification 6-15-160

0000-000-ST-6015  
Custom ID: DCS 6-15  
Revision: 06  
Effective Date: 5/25/2020  
Page 48 of 58

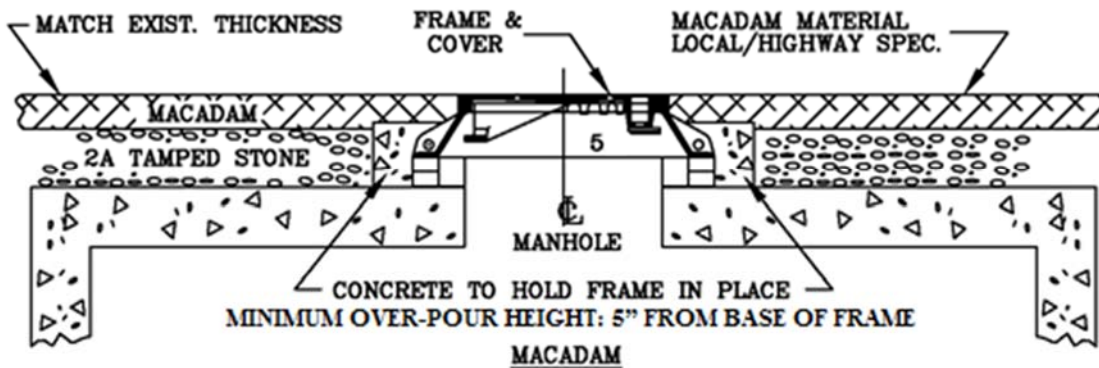
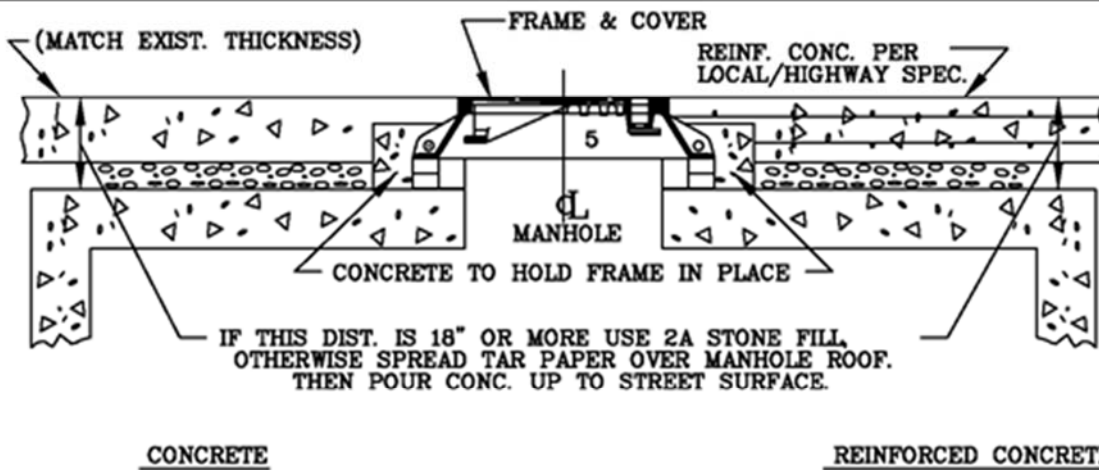
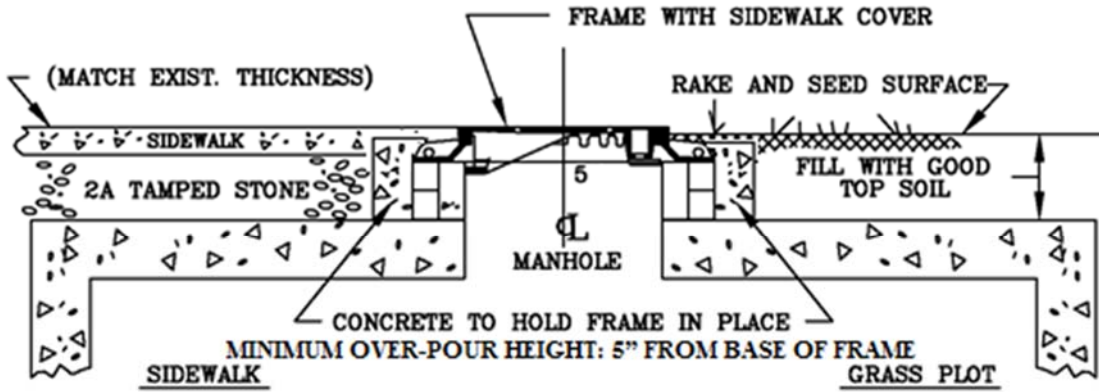

6-15-160-D



**Underground Structural  
Customer Reference Specification  
Customer Installed Duct System  
6-15-180**

0000-000-ST-6015  
Custom ID: DCS 6-15  
Revision: 06  
Effective Date: 5/25/2020  
Page 49 of 58

**6-15-180 – Customer Reference Specification Customer Installed Duct System**

**Customer Installed Duct System**

(Replaces 6-15-181)

THIS CUSTOMER REFERENCE SPECIFICATION (CRS) IS PART OF THE  
RULES FOR ELECTRIC METER AND SERVICE INSTALLATION (REMSI) WEBSITE.





**Underground Structural  
Customer Reference Specification  
Customer Installed Duct System  
6-15-180**

0000-000-ST-6015  
Custom ID: DCS 6-15  
Revision: 06  
Effective Date: 5/25/2020  
Page 50 of 58

This specification contains basic information which defines PPL EU material and design requirements for the construction of concrete encased duct systems.

All details of this specification shall be strictly followed. Any deviation must be approved by a PPL EU engineer. Unapproved deviations are usually costly for the customer to correct and can result in delays or possible refusal to connect service.

**Other Associated Specifications:**

A190974 – Concrete materials specification

A190975 – Concrete placement specification

CRS 6-18-115 – Installation instructions for customer-installed conduit systems on PPL EU terminal Poles.

**Notes:**

When installing duct packs, consideration for future load growth and cable replacement should be given to determine the number of conduits needed. Typically, one spare conduit should be installed for each two planned primary feeders with a minimum of one spare conduit per duct pack.

The installation of new foreign utility or third-party cables or assets in any PPL owned conduits or duct packs is prohibited on the basis of capacity, safety, reliability and engineering considerations. Any necessary installation exceptions or alterations to existing foreign utility or third-party assets in PPL owned conduits or duct packs must be fully reviewed by the Attachments & Telecom Business Services group and will require Director approval.

**1. Construction Plan**

PPL EU will provide the customer with a construction plan showing the proposed location of the underground duct system. Any deviations from the proposed duct route, due to on-site obstructions, must be approved by PPL EU. The customer is responsible for any necessary crossing permits.

**2. Depth of Burial**

Rough grading to within 6 inches of finished grade should be established before trench is dug. Trench must be free of high spots, rock projections, and debris. Minimum depth of cover to top of conduit shall be as follows:

Secondary/service ducts	24 inches
Primary ducts	30 inches
Ducts under roadway	36 inches

### 3. Clearance from Existing Underground Facilities

The clearance between duct systems and existing parallel underground facilities (T.V. cable, telephone cable, gas and water, etc.), shall in no case be less than 24 inches. Duct systems which parallel a steam line shall have a minimum 6 feet separation (can be reduced if ducts are properly insulated).

A duct system which crosses over or under existing underground facilities must have the following minimum clearance:

- Telephone - - - - - 3 inches of concrete or 12 inches of earth
- Gas and water mains - - - - - 12 inches of earth
- Sewers - - - - - 12 inches of earth
- Steam lines - - - - - 6 feet of earth (Can be reduced if duct system has proper thermal insulation.)

If these clearances cannot be obtained, consult the PPL EU engineer prior to construction.

### 4. Joint Trench Electric and Communication

When approved by PPL EU, new electric and communication concrete encased ducts may be installed in a joint trench (see Figure 1). A minimum of 12 inches must be maintained between facilities. A 4 inch solid barrier such as foam board or wood shall be centrally placed between the facilities to create a distinct separation. The barrier shall extend a minimum of 4 inches above the top of the concrete encased duct pack.

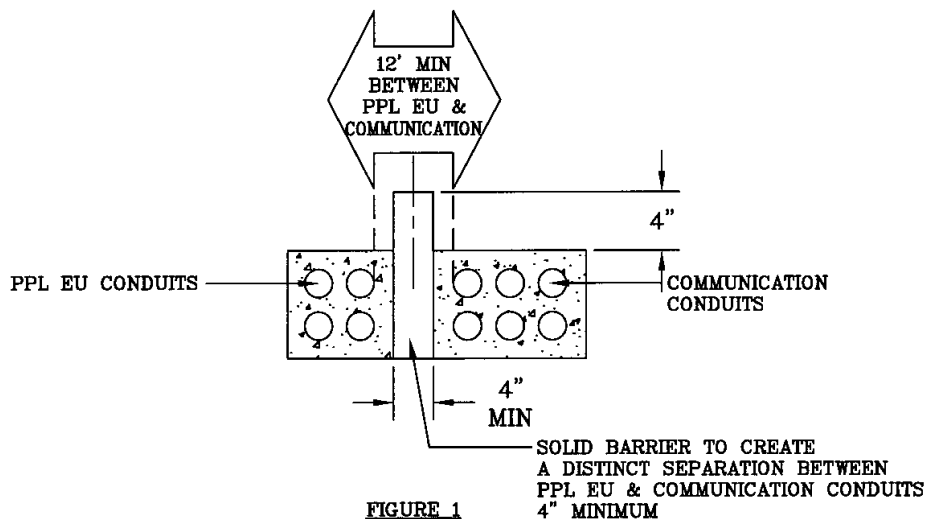

6-15-180-A



**Underground Structural  
Customer Reference Specification  
Customer Installed Duct System  
6-15-180**

0000-000-ST-6015  
Custom ID: DCS 6-15  
Revision: 06  
Effective Date: 5/25/2020  
Page 52 of 58

**Notes: (cont'd.)**

**5. Conduit Types and Sizes**

The minimum size conduit to be used for a duct system is 4 inches. PPL EU will specify the use of 5 or 6 inch conduit when customer installed system is for large diameter primary voltage cables. Aluminum conduits and fittings are not acceptable. The following types of conduits are acceptable for duct pack construction:

<b><u>Type</u></b>	<b><u>Size</u></b>	<b><u>Rating</u></b>
PVC	4", 5", & 6" 4", 5", & 6"	Type I, EB Type II, Gray Schedule 40
Steel	4", 5", & 6"	Rigid or Intermediate

**6. Conduit Bends/Sweeps**

Bends in 4 inch conduit systems shall be minimum 36 inch radius. Bends in 5 or 6 inch conduit systems shall be minimum 48 inch radius. The contractor may use preformed bends or bend conduits at the job site as required. All 90 degree bends must be rigid or intermediate grade galvanized steel.

Sweeps, all gray Schedule 40 PVC sweeps must be a minimum 15 ft. radius.

**7. Couplings**

All PVC conduit couplings must be solidly cemented.

**8. Bell Ends**

All PVC ducts entering manholes, vaults, or transformer foundations shall have bell end fittings. Steel conduits require grounding bushings.

**9. Concrete**

Concrete for encasing ducts shall be 1:2:4 mix (aggregate shall be #1B stone) with a 5 inch slump in accordance with Specification A-190974. High early concrete shall not be used when ambient temperature is above 40°F since the large amount of heat developed in curing may damage or deform the conduits. Allow at least 18 hours to elapse before backfilling trench.



**Underground Structural  
Customer Reference Specification  
Customer Installed Duct System  
6-15-180**

0000-000-ST-6015  
Custom ID: DCS 6-15  
Revision: 06  
Effective Date: 5/25/2020  
Page 53 of 58

**Notes: (cont'd.)**

**10. Conduit Encasement**

Multiple conduits in a duct pack must have base and intermediate spacers placed approximately every 5 feet. The spacers must provide both vertical and horizontal clearance between adjacent conduits (for concrete) of no less than 1-1/2 inches for 4 or 5 inch conduits and 2 inches for 6 inch conduits. PPL EU will inspect the conduit installation prior to concrete being poured.

The trench shall be dug wide enough to allow a minimum 3 inch thick concrete envelope around the conduits. Provide adequate bracing so conduits do not float in wet concrete. Use concrete vibrator tool or other means to ensure the conduits are fully encased in concrete. PPL EU may specify epoxy coated reinforcing rods where soil conditions are unstable. If concrete cannot be poured in one continuous run between ends, taper the first pour so the next pour will bond without creating a shear line.

Allow at least 18 hours to elapse before backfilling trench. Do not backfill with large rocks, broken sections of pavement, construction debris or trash.

**11. Clean Ducts**

All ducts shall be cleaned by pulling a mandrel or stiff bristled brush, followed by a ball of clean rags through the conduits. This procedure will remove earth, sand, stones, or water left in ducts. Seal ends after cleaning.

**12. Pulling Line**

Customer shall install pulling lines. Pulling lines should only be used to enable installing adequate pulling rope. The only acceptable pulling line is a flat polyester, woven, pre-lubed tape, 1/2 inch in width with a minimum breaking strength of 1200 pounds. Allow a minimum of 24 inches of spare pulling line at each end of the conduit run.

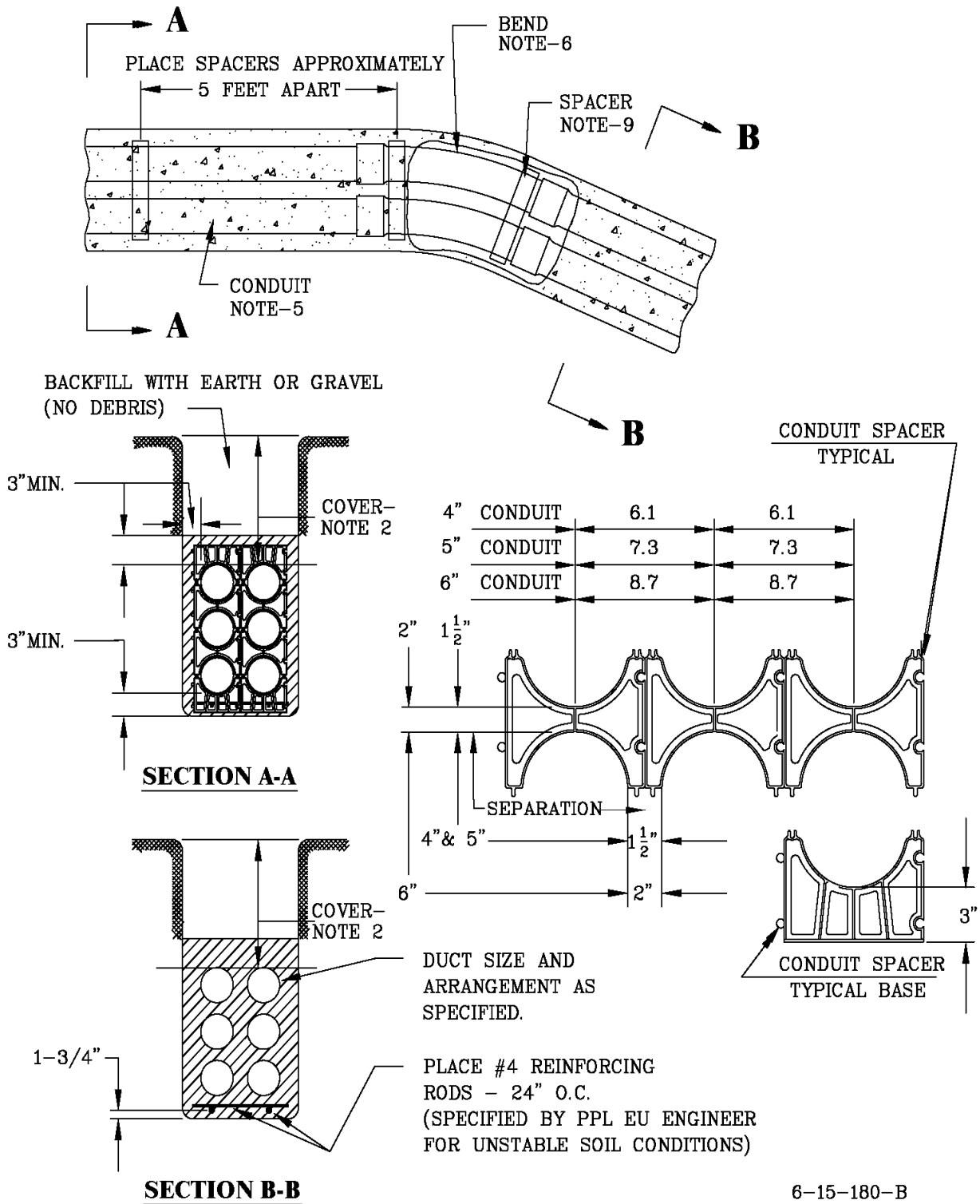

6-15-180-B

**DUCT ENTRANCE AT FIELD POURED MANHOLES AND VAULTS**

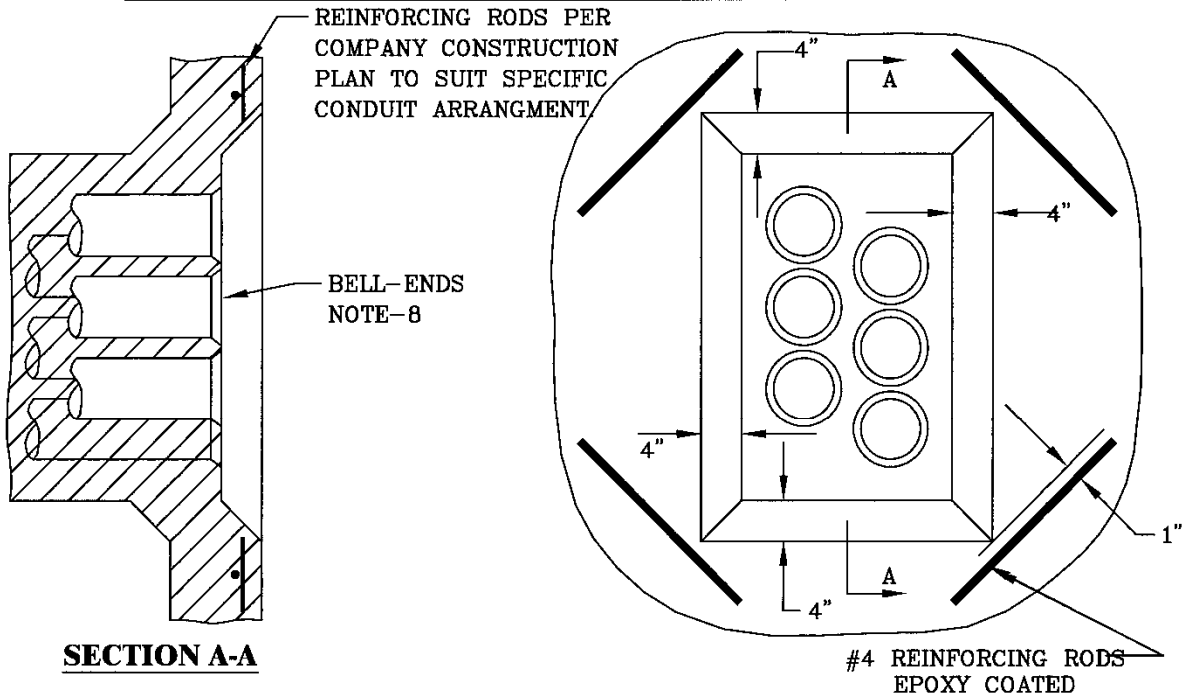

**DUCT ENTRANCE AT PRECAST MANHOLES AND VAULTS**

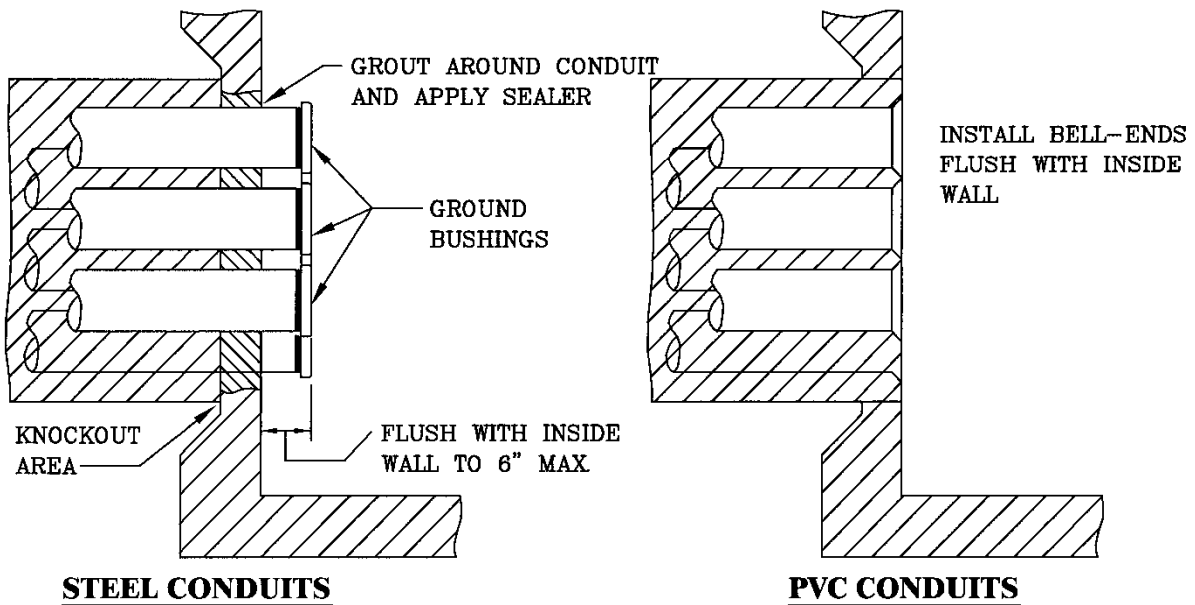

6-15-180-C

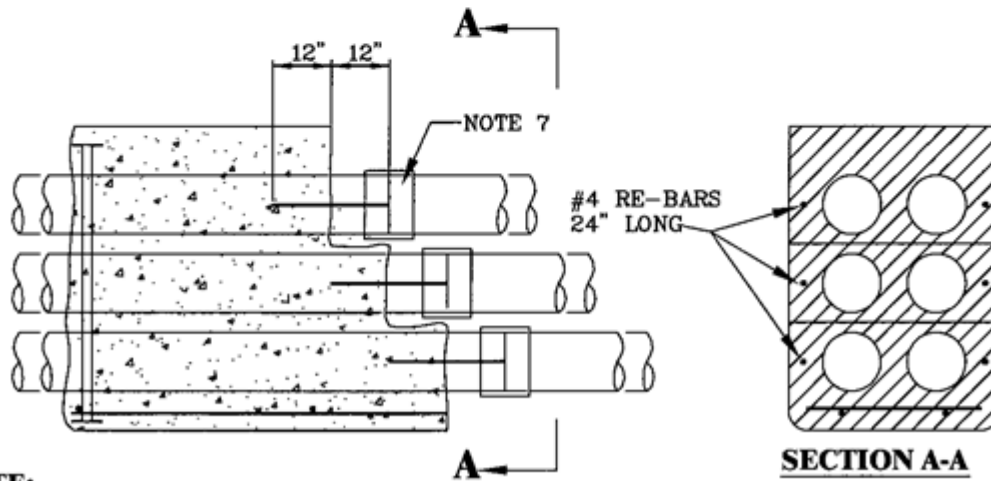
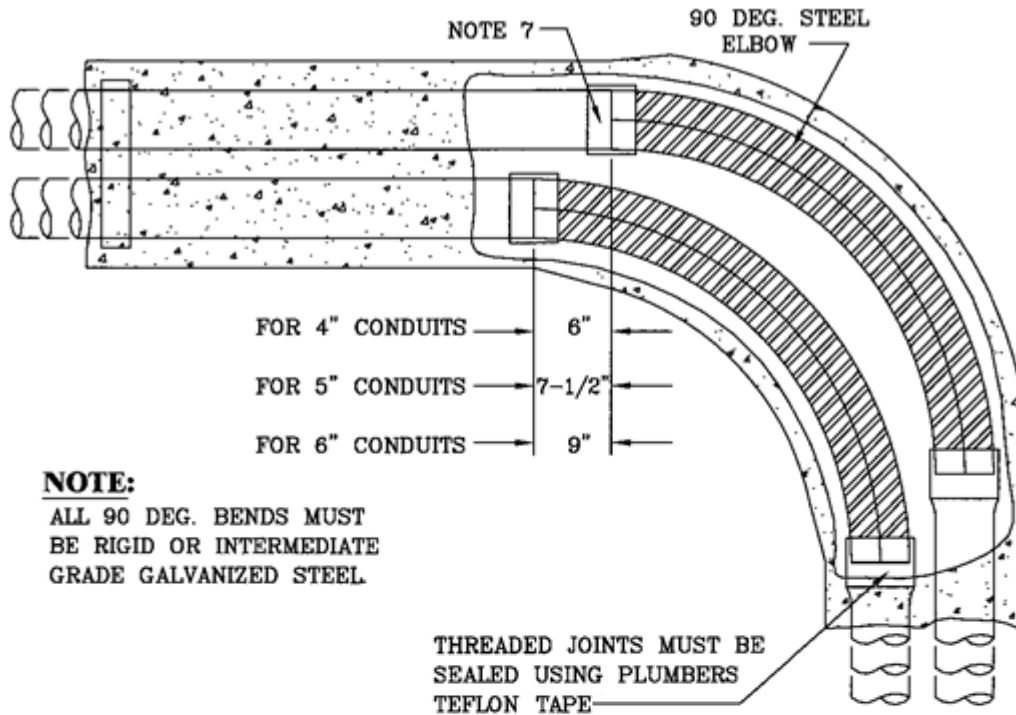

**NOTE:**  
THE DUCT RUN SHOULD BE ENCASED BY MAKING ONE CONTINUOUS POUR. IF SEVERAL POURS ARE NECESSARY, TAPER THE END AS SHOWN ABOVE SO THE NEXT POUR WILL BOND WITHOUT CREATING A SHEAR LINE.

6-15-180-D

**Typical duct cross section**

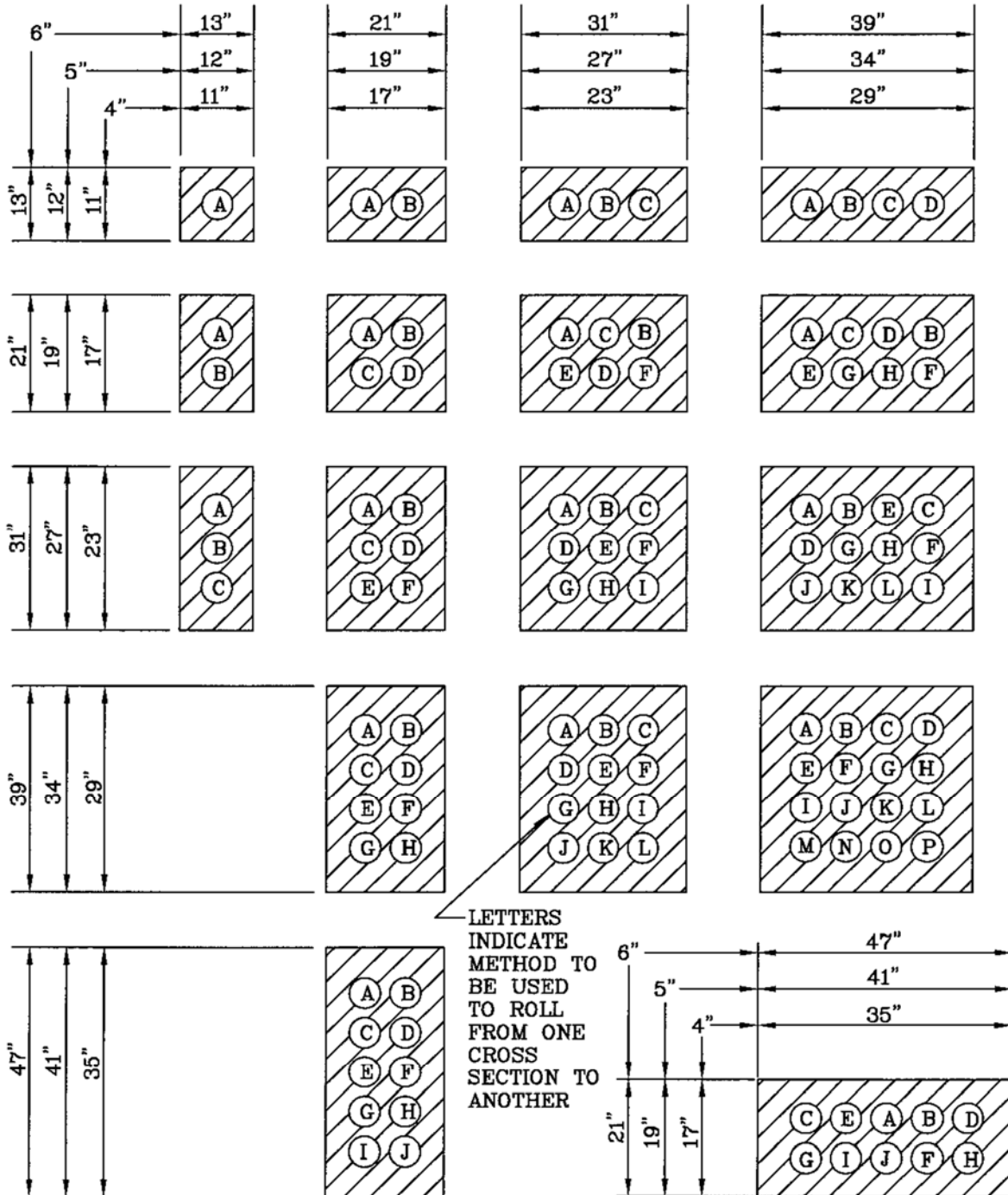



**Typical duct entrance at manholes and vaults**

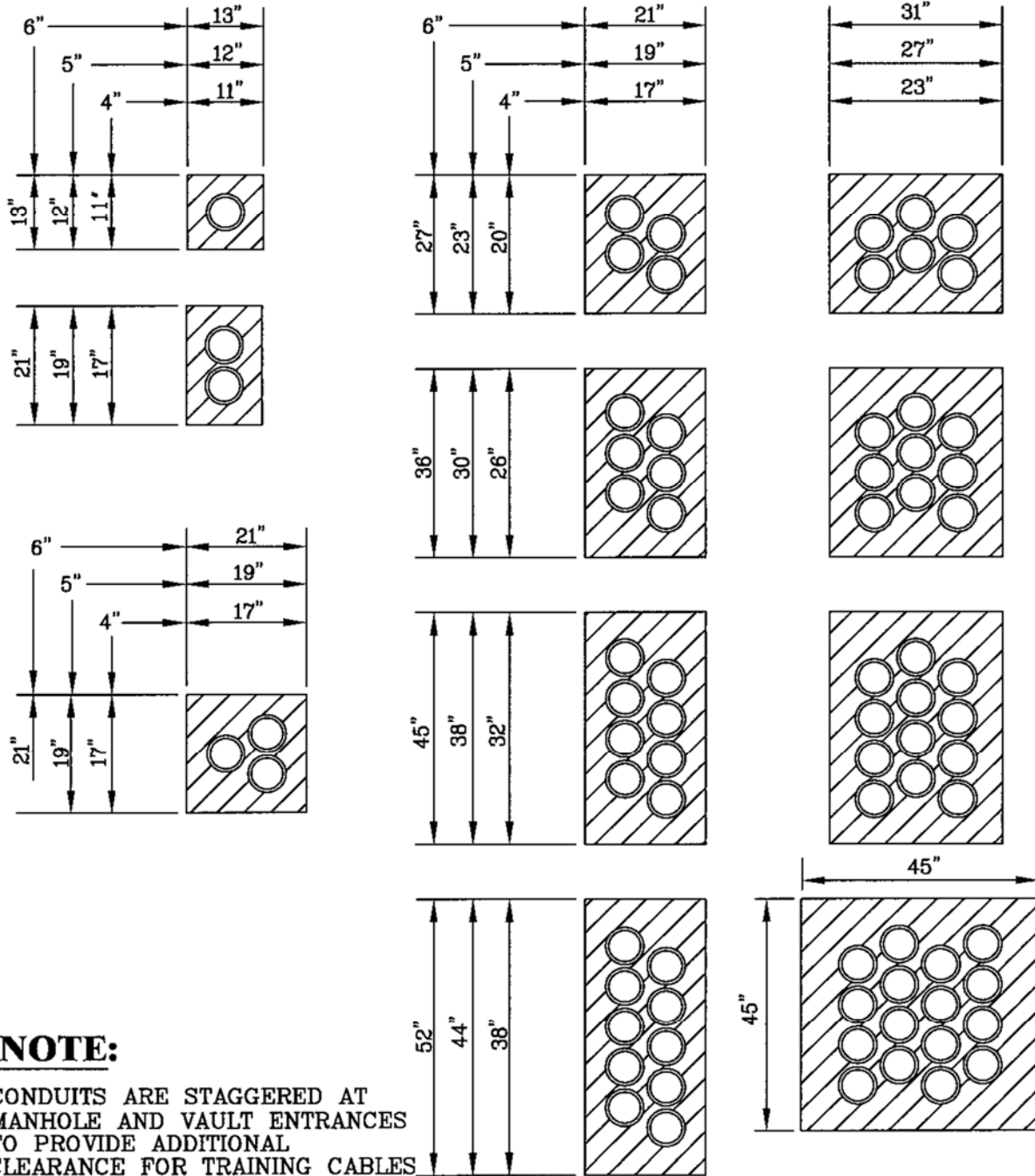

**NOTE:**

CONDUITS ARE STAGGERED AT  
MANHOLE AND VAULT ENTRANCES  
TO PROVIDE ADDITIONAL  
CLEARANCE FOR TRAINING CABLES

**6-15-180-F**