

Sketch #59 Inverter-based renewable generation for DG capacity up to and including 20% of the load center bus bar rating for 12kV metering installations

<u>Voltage:</u> 1 phase, 7200V 3 phase, 4 wire WYE 7200/12,240V	<u>Service Type:</u> Overhead / Underground
<u>Customer Load:</u> 11 MVA maximum	<u>Meter Base Location:</u> Outdoor

PPL EU SERVICE
 POINT OF CONTACT
 12KV NOMINAL

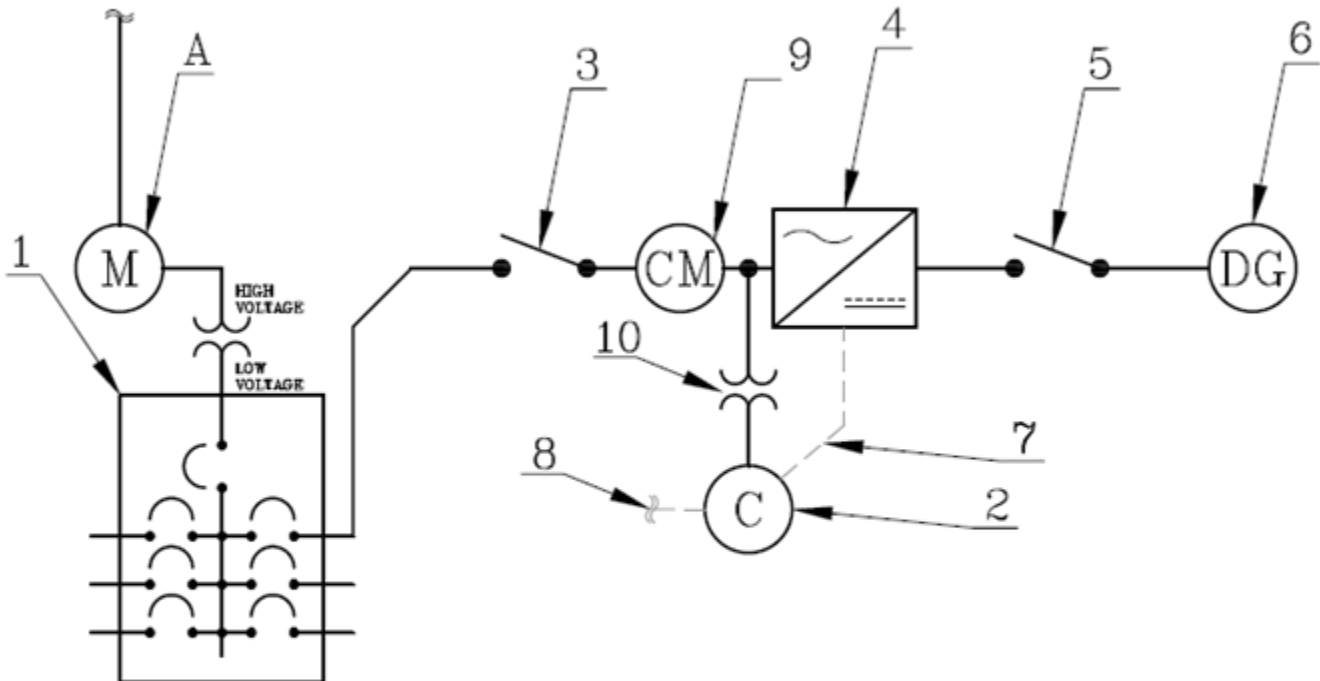

REMSI_S059P1.dwg

RULES FOR ELECTRIC METER AND SERVICE INSTALLATIONS PPL ELECTRIC UTILITIES CORPORATION	Rules: 12, 28 Date: 04/05/2021 Engr: PDP
--	---



**REMSI Sketches 51-100
Sketch #59
6-52**

0000-000-ST-6052
Custom ID: DCS 6-52
Revision: 05
Effective Date: 05/21/2021
Page 40 of 82

Sketch #59 Inverter-based renewable generation for DG capacity up to and including 20% of the load center bus bar rating for 12KV metering installations (cont.)

CUSTOMER FURNISHES, INSTALLS, MAINTAINS:

1. LOAD CENTER
3. AC DISCONNECT SWITCH (FUSED)
4. INVERTER(S) (INCLUDES METERING AND COMMUNICATION FEATURES), INVERTER SHALL BE LABELED AS IEEE 1547/UL 1741 LISTED.
5. DC DISCONNECT
6. DISTRIBUTED GENERATION (DG) SOURCE
9. CUSTOMER METERING (OPTIONAL)

PPL EU FURNISHES, MAINTAINS:

2. ConnectDER™ COLLAR (“SMART” VERSION) WITH 120/240 VAC. ADDITIONAL CONTROL POWER TRANSFORMER MAY BE REQUIRED (10).
7. COMMUNICATION TRANSMISSION BETWEEN COLLAR AND INVERTER (FOR “SMART” VERSION)
8. COMMUNICATION TRANSMISSION BETWEEN COLLAR AND AMI PPL EU (FOR “SMART” VERSION) OR CELLULAR
10. ConnectDER™ POWER TRANSFORMER (IF REQUIRED)

NOTES:

- A. METERING EQUIPMENT. SEE APPROPRIATE SKETCH FOR SERVICE TYPE AND SIZE TO DETERMINE METERING RESPONSIBILITIES.
- B. SEE PPL EU CUSTOMER-OWNED GENERATION WEBSITE FOR MORE INFORMATION.
- C. APPLICATION FOR CUSTOMER-OWNED, INVERTER-BASED RENEWABLE GENERATION MUST BE COMPLETED. SEE CUSTOMER-OWNED GENERATION APPLICATIONS.
- D. PPL EU REQUIRES AN INDEPENDENT ELECTRICAL INSPECTION. THE INSPECTOR IS REQUIRED TO VERIFY THE IEEE/UL LISTING OF THE INVERTER.
- E. INSTALLATION MUST ADHERE TO REQUIREMENTS OF NATIONAL ELECTRICAL CODE ARTICLE 690 AND ARTICLE 705.

REMSI_S059P1.dwg

<p>RULES FOR ELECTRIC METER AND SERVICE INSTALLATIONS PPL ELECTRIC UTILITIES CORPORATION</p>	<p>Rules: 12, 28 Date: 04/05/2021 Engr: PDP</p>
---	---



REMSI Sketches 51-100
Sketch #59
6-52

0000-000-ST-6052
Custom ID: DCS 6-52
Revision: 05
Effective Date: 05/21/2021
Page 41 of 82

Sketch #59 Inverter-based renewable generation for DG capacity up to and including 20% of the load center bus bar rating for 12KV metering installations (cont.)

- F. ALL LABELING MUST BE IN ACCORDANCE WITH NEC ARTICLE 690.
- G. IN ADDITION TO NOTE D, PPL EU WILL INSTALL PERMANENT LABELING ON THE METER BASE PPL EU CATALOG (CID 1012171) AND PAD MOUNT TRANSFORMER (CID 1012171) OR POLE MOUNT TRANSFORMER (CID 1013816) UPON RECEIPT OF INSPECTION.
- H. SEE REMSI SKETCHES #30, SKETCH #31. SKETCH #33, & SKETCH #34.
- I. IF A NEUTRAL CONNECTION EXISTS AT THE INVERTER, THE INVERTER NEUTRAL SHALL BE CONNECTED TO THE SERVICE NEUTRAL.
- J. CUSTOMER SHALL CONTACT PPL EU PRIOR TO ANY NEW INSTALLATIONS DEPICTED IN THIS SKETCH.
- K. **PPL REQUIRES A LOCAL RS-485 OR ETHERNET COMMUNICATION INTERFACE, ALSO REFERRED TO AS A COMMUNICATION PORT, TO BE OPEN AND ACCESSIBLE FOR THE COMPANY OWNED DER MANAGEMENT DEVICE (IEEE 1547-2018, SEC. 10.1,4).**
- L. **INSTALLATIONS WITH MULTIPLE INVERTERS SHALL BE NETWORKED TOGETHER BY THE CUSTOMER PER MANUFACTURER GUIDELINES OR RS-485 MULTIDROP NETWORKING. A COMMUNICATION NETWORK DIAGRAM DEPICTING PORT AVAILABILITY AND NETWORKING DESIGN SHALL BE INCLUDED WITH THE SYSTEM'S INTERCONNECTION APPLICATION.**
- M. **FOR INVERTERS WHERE AN ADDITIONAL MODULE OR KIT IS REQUIRED TO MAKE THE COMMUNICATION INTERFACE/PORT AVAILABLE, THE MODULE OR KIT MUST BE INCLUDED AS PART OF THE INSTALLED SYSTEM. REFERENCE PPL'S APPROVED SOLAR INVERTER LIST FOR SPECIFIC INFORMATION.**

REMSI_S059P1.dwg

<p>RULES FOR ELECTRIC METER AND SERVICE INSTALLATIONS PPL ELECTRIC UTILITIES CORPORATION</p>	<p>Rules: 12, 28 Date: 04/05/2021 Engr: PDP</p>
---	---